

Septic 200 – Magnelis – Mounted Pump-Out Station FIP 400V (PN 11-01-001) and FIP 240V (PN 11-01-002)

Albinex's Septic 200 mounted pump-out stations are self-contained pumping units developed for the land-based emptying of septic tanks on boats; as well as for certain septic tanks installed in tourist busses, caravans/camper trailers and motorhomes/campers.

The septic tanks must be intended for emptying by means of suction and the deck fittings/connections must be compliant with ISO/DIS 8099.3 or ISO 4567 for the most efficient vacuum evacuation.

The sole intended application for the Septic 200 Pump-Out Stations is the emptying of septic tanks. ***Under no circumstances are the Septic 200 Pump-Out Stations to be used for the pumping of oil, diesel, gasoline or other flammable liquids!***

The Septic 200 Pump-Out Stations come pre-assembled, ready to attach to the dock and include the following:

- Complete discharge self-priming pump of flexible impeller-type, modified by Albinex specifically for the emptying of septic tanks; mounted in a sturdy stainless-steel frame
- Integrated vacuum switch
- Integrated electrical connection box with wiring to control panel, pump and vacuum switch
- Protective housing of sheet Magnelis® Steel, for extra corrosion resistance
- Complete 7 m (23 ft) suction hose, with hose connector ports, handle and control valve for pump-out, and rubber suction cone

Installation

- 1) Determine the optimum position along the dock for placement of the Pump-Out Station.

The suction performance of any pump is determined by the viscosity of the media being pumped, length of the suction hose, head/back pressure, motor speed and inner diameter of the hoses. Therefore:

- Locate the Pump-Out Station as close as possible to the designated mooring point for septic tank emptying (a longer (10 m (32.8 ft)) suction hose is available as an accessory)
 - Keep the lifting height required as low as possible (the pump is capable of max. 3 ½ m (11.5 ft) suction lift)
 - Shorter suction hoses and lower suction lift will increase the life expectancy of the flexible impeller and seals
 - If possible, minimize the length of the discharge hose to the holding tank/sewage lines, avoiding bends in the discharge hose, which could lead to the clogging of the hose.
 - Use only hoses with the rated diameter; either approved by or supplied by Albinex
 - Additionally, allow for ample mooring space for larger boats along the dock
- 2) Unscrew the nine (9) mounting screws holding the service cover on the narrow side of the Station, opposite the side with the suction and discharge hose connection ports. (See Fig. 1)
 - 3) Remove the service cover
 - 4) Loosen the retaining bolts (13mm socket) fixing the frame to the transport pallet
 - 5) Position the Pump-Out Station in the desired location and securely fasten it to the dock. Note!, The pump must NOT be installed in an environment with flammable liquids, gases, etc. If you are at all uncertain, confer with the fire department and local authorities as to the regulations and bylaws.
 - 6) Replace the service cover and secure it with the 9 mounting screws. (See Fig. 1)
 - 7) Connect the discharge hose to the discharge port on the Pump-Out Station

Electrical installation

All electrical work on the Pump-Out Station is to be carried out a certified electrician!

Make sure that the power is turned off before attempting any electrical work on the Pump-out Station!

From the site's power station, run an appropriately dimensioned power cable off of a 16A fuse and earth fault circuit breaker to the Pump-Out Station's supplied terminal.

Operation of the Septic 200 Pump-Out Station

- 1) Unwind the suction hose from the holder on the Station and bring the suction nozzle to the septic tank to be emptied, make sure there are no kinks or unnecessary bends in the hose.
- 2) Open the shut-off valve located on the suction nozzle handle by turning the valve so that the handle of the valve is parallel to the length of the hose. (See Fig. 2)
- 3) Connect the rubber cone of the suction nozzle securely to the septic tank deck fitting. It is the boat owner's/vehicle owner's responsibility to be acquainted with the construction of their septic tank and that it is - in fact - designed for suction emptying. Make sure that the suction nozzle is securely pushed into the deck fitting, giving an airtight connection. Otherwise, the suction power will be severely reduced; in the worst case the tank cannot be emptied at all.

- 4) Open the sliding door to the control panel. A red light will indicate that the pump is ready for use.
- 5) Press the green button and hold it in until the green light comes on, indicating that the pump is running, and the vacuum switch is activated. Release the button.
- 6) The pump will shut down automatically, via a time relay that is factory set for 40 seconds – the normal time required to empty a septic tank of 60 – 100 liter. If larger tanks are commonly emptied, the time relay can be modified. Figure in that 2 – 2.5 liters can be pumped per second (dependant on hose length and pumping height). If the tank is emptied before the time relay kicks in, the vacuum valve senses that the tank is empty (starts sucking air) and automatically shuts down the pump. **NB! Never attempt to force start the pump after it has stopped. Do NOT attempt to run the pump if the tank is empty!** By the nature of a flexible impeller pump, the pumped media is required to lubricate the impeller and the mechanical seals. By “dry running” the pump – i.e., operating the pump empty of liquid – for more than 30 seconds, the impeller and seals will be damaged. During start-up the pump will be running dry for a few moments as it sucks the liquid up from the septic tank to the pump; this is normal – however, the shorter the suction hose and the lower the suction lift height, the less time the pump will be dry running. This will save wear and tear on the pump.
- 7) If, for some reason, the pump fails to shut down, press the red button to manually shut down the pump. Service personal must then investigate why the pump did not shut down automatically.
- 8) When the tank is empty remove the nozzle from the deck connection and immerse the nozzle a bit into the water. Run the pump again for approx. 10 seconds to flush out the hose. Pull the nozzle out of the water and the vacuum valve shuts off the pump.
- 9) **Close the shut-off valve on the suction nozzle handle by turning the valve so that the handle of the valve is perpendicular to the length of the hose. (See Fig. 2)**
- 10) Close the door to the control panel on the Pump-Out Station.
- 11) Return the hose to the pump/Pump-Out station and rewind the hose onto the holder for the next user and avoid kinks or other damage to the hose and suction nozzle/handle.

Service, maintenance and winterization

Before any service or maintenance is carried out on the Septic 200 Pump-Out Station make sure that all electrical power from the site's power station to the Pump-Out Station is disconnected! Any electrical work on the electric motor of the pump or the electrical connection box and control panel is to be carried out by a certified electrician!

Reparations of the pump or motor may invalidate the warranty, please contact your Albinex representative.

Wear parts, such as the impeller, O-ring seal for the pump cover or the mechanical seals, may be replaced by the end user.

- 1) Unscrew the nine (9) mounting screws holding the service cover on the narrow side of the Station, opposite the side with the suction and discharge hose connection ports. (See Fig. 1)
 - 2) Remove the service cover to access the pump
- Before any work is performed on the pump, the pump must first be drained.
 - 3) Unscrew the two locking nuts holding the pump cover in place and remove the cover.

• Impeller replacement

- 4) Remove the impeller by pulling it out with a special impeller pulling tool (Albinus 06-03-035) or polygrip pliers.
- 5) Clean the inside of the pump house
- 6) Lubricate the new impeller with some glycerin or dishwashing liquid and insert the impeller by gently pushing it in, with a twisting motion, so that the flexible vanes of the impeller conform to the eccentric shape of the pump house.
- 7) Examine the O-ring seal on the pump cover, replace with a new O-ring if necessary.
- 8) Replace the pump house cover and tightly secure it with the two locking nuts.
- 9) Replace the service cover and secure it with the nine mounting screws. (See Fig. 1)
- 10) Reconnect the power to the Pump-Out Station

• Mechanical seal replacement

- 4) Temporarily loosen the electric wiring to the vacuum switch and remove the hose connections from the pump's suction and discharge ports and pull the entire pumphouse free from the motor mounting bracket. **Make note of which hose and port is which!**
- 5) Remove the impeller by pulling it out with a special impeller pulling tool or a polygrip. (*you have removed the pump cover in step 3 above*)
- 6) Press the stationary part of the mechanical seal out of the pump house and remove its O-ring
- 7) Remove ceramic washer, loosen the set screw holding the rotating part of the mechanical seal in place and remove the rotating part of the seal from the pump shaft
- 8) Clean the inside of the pumphouse and the pump shaft
- 9) Carefully press the rotating part onto the pump shaft, taking care not to damage the seal face. Tighten the set screw and replace the ceramic washer.

- 10) Replace the O-ring for the stationary part of the seal, then lubricate the stationary part of the seal with some glycerin or dishing washing liquid and gently press it into place in the pump house; again, taking care not to damage the seal face. **NB! Never use lubricating oil, grease or other petroleum product in the pumphouse.**
- 11) Slide the pumphouse back onto the pump shaft and mounting bracket, taking care not to damage the seal face with the shaft.
- 12) Replace the impeller with a new one if needed.
- 13) Lubricate the new impeller with some glycerin or dishing washing liquid and insert the impeller by gently pushing it in, with a twisting motion, so that the flexible vanes of the impeller conform to the eccentric shape of the pump house.
- 14) Examine the O-ring seal on the pump cover, replace with a new O-ring is necessary.
- 15) Replace the pump house cover and tightly secure it with the two locking nuts.
- 16) Reconnect the suction and discharge hoses with the correct ports on the pumps.
- 17) Reconnect the wires to the vacuum switch
- 18) Replace the service cover and secure it with the nine mounting screws.
- 19) Reconnect the power to the Pump-Out Station

If the pump has gone unused over a longer period of time you should flush the pump and hoses through with clean water as well as starting the pump from time to time, running sea water through it.

If the suction hose or its fittings have been damaged through incorrect or rough handling, use only a hose type approved by or supplied by Albinex. Likewise use only original wear parts supplied by Albinex.

Winterize your Pump-Out Station

Prepare your Septic 200 Pump-Out Station by the following:

Visually inspect your pump

- Check that everything is whole and complete
- If anything is broken, worn out or needs to be replaced before the next season, order parts via www.albin.group or via email info@albin.group
- All spare parts are kept in stock for quick delivery

Conserve your Pump-Out Station for Winter

- Fill a bucket with 4 liters of 50% Environmentally friendly Glycol
- Open the shut-off valve on the suction nozzle handle (See Fig. 2)
- Place the suction nozzle in the bucket with Glycol
- Start the pump and let it run until it stops
- The pump is now conserved for the Winter

Conserve the discharge hose to the holding tank or sewage line

- Lay out the hose straight on the ground with the valve open
- Start the pump again and manually shut off the pump after five seconds
- The discharge hose is now conserved for the Winter
- Shut off the power to the Station

Complete the winterization of your Pump-Out Station:

- Remove the hose to reduce wear on the hose and rubber cone
- Plug the hose connection with something so that no foreign objects enter the pump
- Turn off the power to the Pump-Out Station

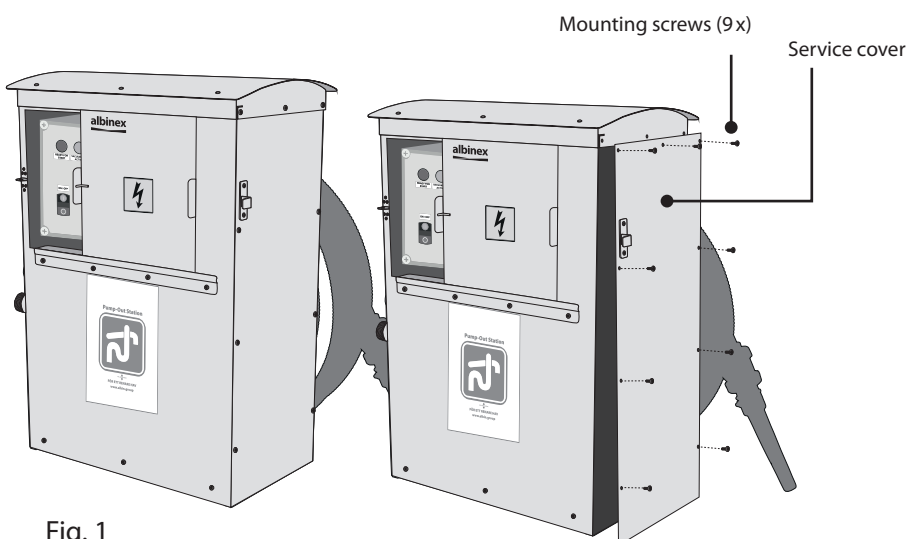

Fig. 1

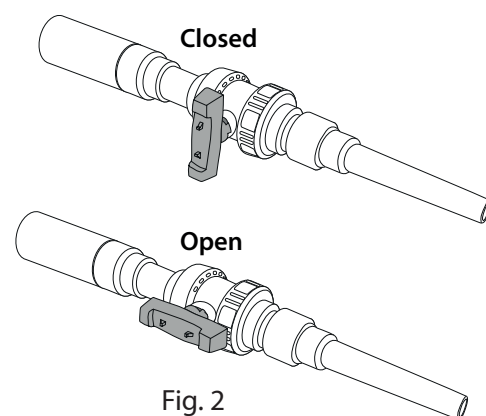

Fig. 2

Trouble shooting

Type of problem	Action
Pump does not start	
No electricity	Check and if necessary, replace fuse Check the power grid, overload, etc.
Voltage too low	Check the wiring dimensions
Abnormal swelling of the impeller	The pump has probably been used to drain oil or other petroleum products, replace impeller (the Neoprene impeller is NOT oil-resistant)
No suction	
Wrong rotational direction	Check the wiring Check that the suction hose is connected to the suction port of the pump
Loose pump cover locking nuts	Tighten the nuts
Worn out pump cover O-ring	Replace O-ring
Blocked suction/discharge port	Disassemble and flush clean the pump and connections, check that the shut-off valve is open
Suction lift height too high	Reduce the suction lift height or fill the suction hose and pump up with water
Air leaks in suction hose	Make sure that the suction nozzle is correctly connected to the deck fitting. Check the hose for damage and loose connections.
Damaged or worn out impeller	Replace impeller
Ceramic washer/pump cover worn out worn out mechanical shaft seal	Replace worn out parts
Leaking pump	
Worn out seals	Replace seals
Insufficient flow	
Worn out pump	Replace wear parts: pump cover, impeller, seals, cover O-ring
Air leaks on the suction side	Check the hose for damage and loose connections and that the suction nozzle is properly connected to the deck fitting

Technical data

Pump	1½" (40 mm) Flexible Impeller Bronze Pump head
Motor	FIP400V PN: 11-01-001: 3-phase, 400 V, 1.5 kW, 50 Hz, average amp. draw 5 A, Fuse 8 A FIP240V PN: 11-01-002: 1-phase, 240 V, 2.2 kW, 50 Hz, average amp. draw 12 A, Fuse 16 A
Shaft seal	Single Mechanical seal
Max. suction lift	3½ m (11.5 ft)*
Max. pressure	Approx. 3½ bar (50.8 psi)*
Max. distance to discharge	200 m
Max. flow	Approx. 150 l/min (40 GPM)*

* Pumping water

Materials

Pumphouse	Marine grade Bronze
Pump cover	Stainless steel
Protective housing	Magnelis® Steel
Impeller	Neoprene
Suction hose length	7 m (23 ft)

Dimensions and Weight

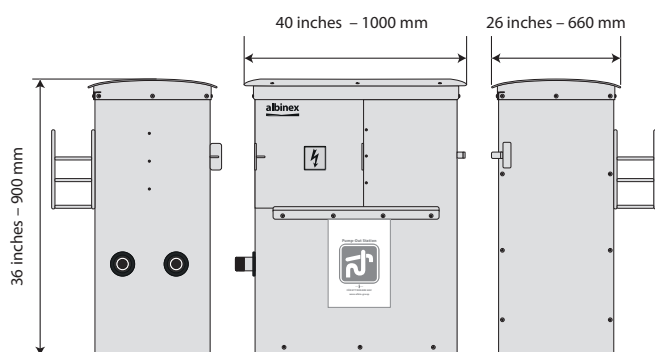

Weight 165 lbs – 74.5 kg

Common Spare Parts

PN	Description
11-99-004	Replacement hose cone for ISO/DIS 8099.3 or ISO 4567 compliant deck fittings
11-99-005	Hose cone connection handle with shut-off valve
11-99-006	Hose connection port for connecting hose to Pump Out Station
05-93-032	Premium Spare Parts Kit for the FIP 40 discharge pump; includes Impeller replacement kit, wear parts and fasteners required for the pump
05-63-053	Vacuum switch for automatic discharge pump shut down, replaced Part nr. 11-99-011
11-99-012	Small service kit containing 1x Rubber cone, 1x Impeller & 1x pumpout sign
11-99-013	Large service kit containing 1x Rubber cone, 3x Hose clamps, 7m Hose, 1x Hose connection seat, 1x Hose connection port, 1x Impeller and 1x Vacuum switch
11-99-014	Pumpout hose kit, 7 m with Hose Cone Connection Handle, Rubber cone and Hose Connection Port
11-99-015	Pumpout hose kit, 10 m with Hose Cone Connection Handle, 2x Rubber cone and Hose Connection Port

For additional spare parts, refer to website
<https://albin.group/product-category/pump-out-systems>

Albin Group AB
Kämpvägen 17
55302 Jönköping, Sweden
www.albin.group
info@albin.group

Albin Group

since 1928